

## HJB 90 T4 0,55kW (509111034)

### GENERAL DATA



BELT DRIVE AXIAL FAN FOR HUGE AIR FLOW

MANUFACTURING FEATURES:

- Completely made of galvanized steel sheet.
  - Equipped with gravity shutter.
  - Stainless steel impeller (AISI 430).
  - Protection grid on pulley area.
  - Standard asynchronous squirrel-cage motor with IP-55 protection and class F insulation.
- Manufactured with standard voltage: 230/400V 50Hz
- Internal wiring box. Inspection door for motor access.

APPLICATIONS:

Designed for wall assembly, they are suitable for:

- Air renewal in buildings and industries.
- Farms and greenhouses.
- Maximum working temperature: 50°C.

UNDER REQUEST

Option 60Hz

### PERFORMANCE CURVE

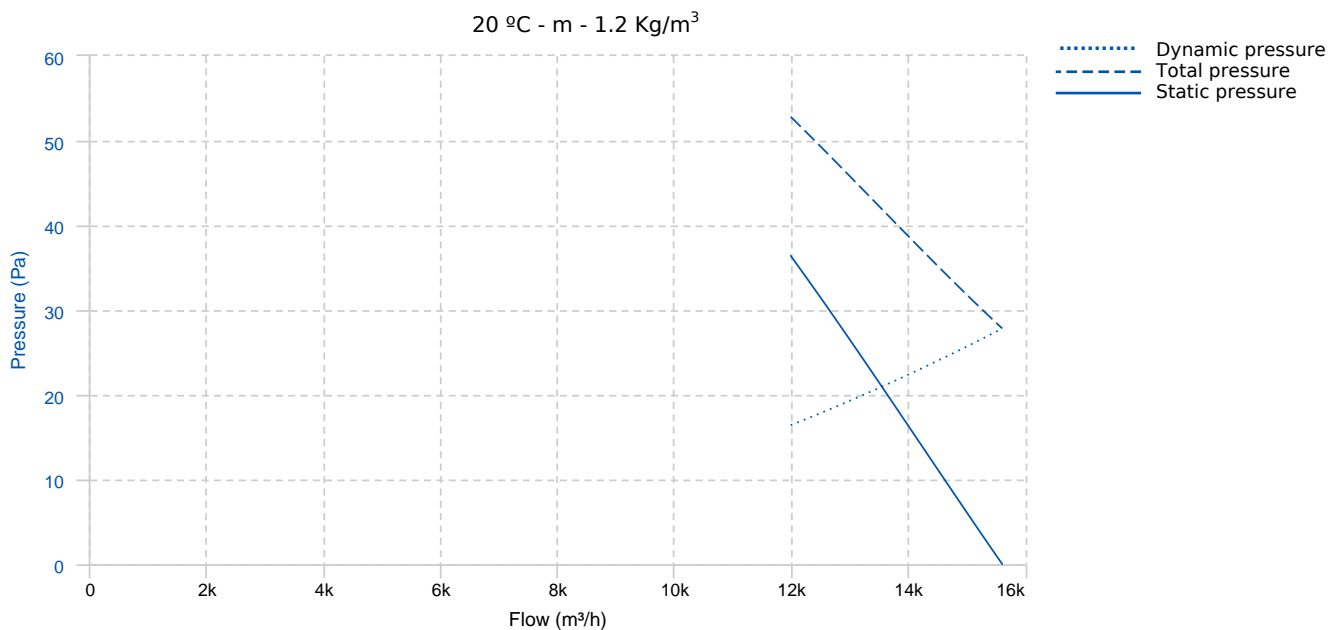

### TECHNICAL DATA

Fan							
RPM	1390	Approx. weight	40 kg	Max. Flow	15600 m³/h		
Motor							
Power	0,55 kW	RPM	1390	I max. (230V)	2,5 A	I max. (400V)	1,4 A
Approx. weight	8.3 kg						

**DIMENSIONS**

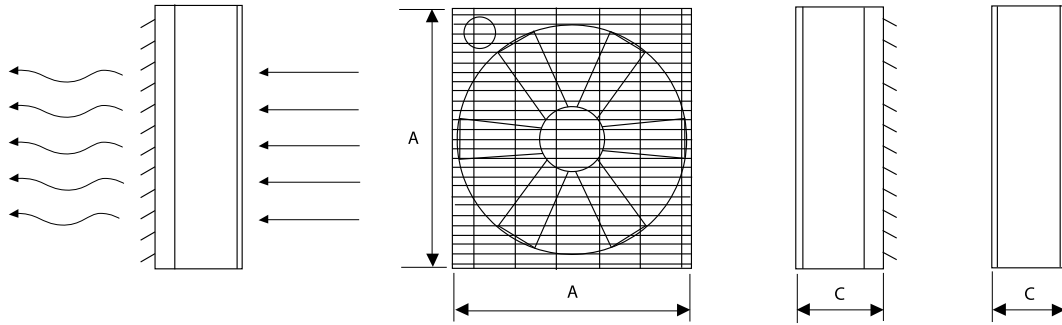

**Dimensions (mm)**

A	900	C	400
---	-----	---	-----

**WIRING DIAGRAM**

230V

400V

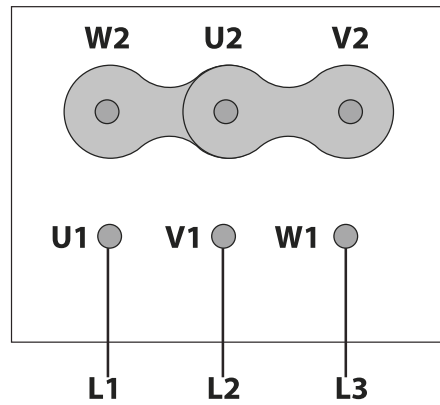
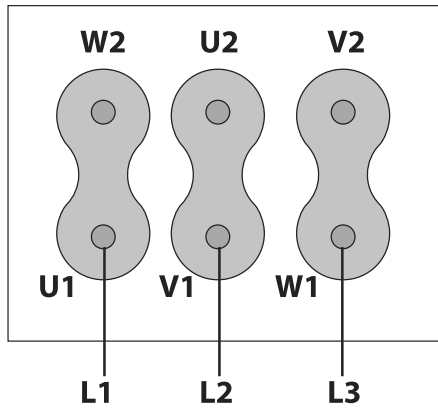

**ACCESSORIES**

**SPARE PARTS**

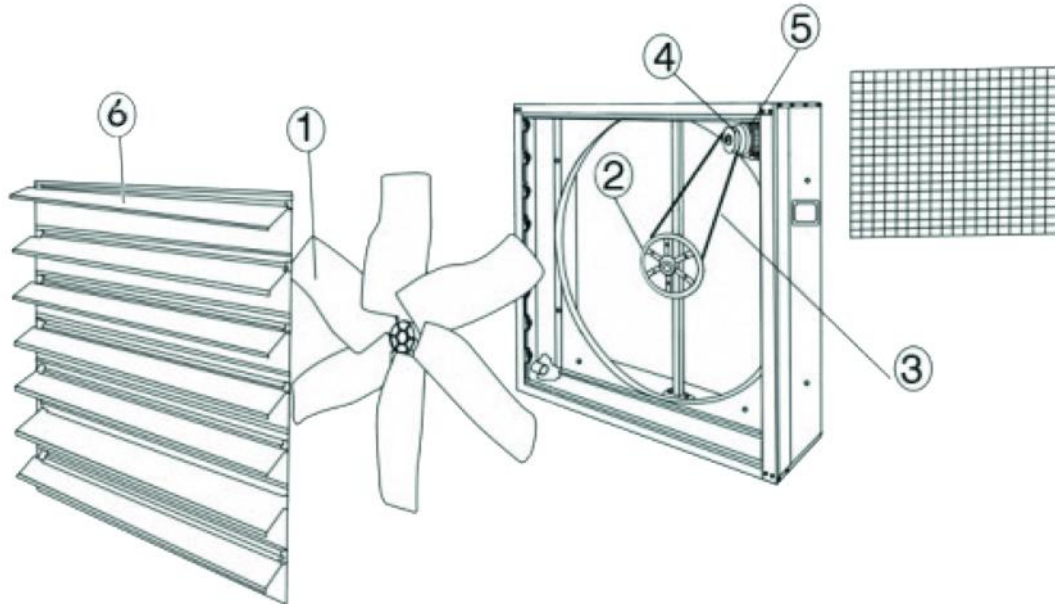

	Code	Model	Qty
1	509111034SP20	IMPELLER HJB 90	x1
2	509111034SP21	PULLEY+BEARING HJB90	x1
3	509111034SP16	BELT HJB90 (SPA 1346)	x1
4	509111034SP14	PULLEY HJB90 (SPA 85)	x1
5	509111034SP15	MOTOR 0,55kW T4 B3 230/400V (HJB 90)	x1
6	509111034SP17	SHUTTER SLAT HJB90	x5